















Through Bolts

Technical Specifications



Through Bolts product overview

| | BA-V Plus | BA-F Plus | BA-E Plus |
|-----------------------|--|---|--|
| Anchor |  |  |  |
| Material | Carbon steel Zinc electroplated | Carbon steel Hot dip galvanized | Stainless steel A4 |
| Applications | Dry indoor conditions, indoor with temporary condensation | Humid indoor use, outdoor inland rural areas only in not safety relevant applications | For indoor, outdoor, industrial use and maritime climate. |
| Base materials | Cracked concrete Non-cracked concrete | Cracked concrete Non-cracked concrete | Cracked concrete Non-cracked concrete |
| Thread size* | M8, M10, M12, M16 | M8, M10, M12, M16 | M8, M10, M12, M16 |
| Tools | Setting tool BA | Setting tool BA | Setting tool BA |
| Technical data |  F120  C1/C2 |  F120 |  F120  C1/C2  Rostfrei STAINLESS STEEL |
| Approvals |  ETA CE ETA-16/0934  ETA CE ETA-18/0219 |  ETA CE ETA-16/0934  ETA CE ETA-18/0219 |  ETA CE ETA-16/0934  ETA CE ETA-18/0219 |

Note: Diameter M6 for multiple use for non-structural applications in concrete available on demand. BA-E Plus HCR available on request

BA-E Plus HCR

BA-C NC



Stainless steel
HCR 1.4529 / 1.4565

Carbon steel
Zinc electroplated

HCR for extremely corrosive conditions,
such as high chlorine concentrations
(swimming halls) road tunnels and
desulphurization plants

Dry internal conditions

Cracked concrete
Non-cracked concrete

Non-Cracked concrete \geq C20/25
"Option 7"

M8, M10, M12, M16





M8, M10, M12, M16

Setting tool BA

Setting tool BA



Approvals / Certifications / Applications

| Description of document | | Authority/ Laboratory | ID | Additional info |
|--------------------------------------|---|---|---|---|
| European Technical Assessment |  | ZAG -National Building and Civil Engineering Institute, Slovenia ETA Danmark A/S | BA Plus: ETA-16/0934 ETA-18/0219 BA-C-NC: ETA-20/0286 | EAD 330232-01-0601 |
| Fire resistance |  | ZAG -National Building and Civil Engineering Institute, Slovenia | ETA-16/0934 ETA-18/0219 | EOTA TR 020 / EN 1992-4 |
| Seismic resistance |  | ZAG -National Building and Civil Engineering Institute, Slovenia | ETA-16/0934 ETA-18/0219 | EOTA TR 045 BA-V Plus / BA-E Plus anchor size M8 – M16: C2 |
| EJOT Anchor Fix calculation software |  | EJOT Software |  | Free download: https://www.ejot.com/software-anchorfix |

Additional information concerning all given data in the product data sheet

- > Load figures include the partial safety factors as per approvals and a partial safety factor on the action of $\gamma_{F=}$ 1.4. Load figures apply for a rebar spacing $s \geq 15$ cm or alternatively for a rebar spacing $s \geq 10$ cm in combination with a rebar diameter of $d_s \leq 10$ mm.
- > If spacings or edge distances become smaller than the characteristic figures ($s_{cr,N} / c_{cr,N}$) a calculation as per EOTA TR 055 needs to be carried out. For more details, see ETAs.
- > Concrete is considered non-cracked when the value of tension within the concrete is $\sigma_L + \sigma_R \leq 0$. In the absence of detailed verification $\sigma_R = 3$ N/mm² can be assumed (σ_L equals the tension within the concrete as a result of external loads, forces on anchor included; σ_R equals the tension coming from shrinkage or creep of the concrete, as well as displacements of supports or temperature variations).
- > Shear load figures apply for an anchor without influence of a concrete edge. For shear loads close to an edge ($c \leq 10 \times h_{ef}$), concrete edge failure has to be checked as per EOTA TR 055.

Static and quasi-static loads

Characteristic resistances

| Anchor size | | M8 x 50 ¹ | M8 [Opt. 7] | M8 | M10 | M10 [Opt. 7] | M12 | M16 | | | | |
|------------------------------------|---------------------------|----------------------|----------------|------|-------|-----------------|-------|-------|------|-------|-------|-------|
| Effective anchorage depth h_{ef} | | [mm] | 23 | 43 | 35 | 48 | 40 | 60 | 50 | 50 | 70 | 85 |
| Non-cracked concrete | | | | | | | | | | | | |
| Tensile N_{Rk} | BA-V Plus / BA-F Plus | [kN] | - | - | 8.0 | 11.0 | 12.0 | 19.0 | - | 17.4 | 25.0 | 36.0 |
| | BA-E Plus / BA-E Plus HCR | [kN] | - | - | 8.0 | 11.0 | 12.0 | 19.0 | - | 17.4 | 25.0 | 36.0 |
| | BA-C NC | [kN] | 4.3 | 11.0 | - | - | - | - | 13.0 | - | 17.0 | 22.0 |
| Shear V_{Rk} | BA-V Plus / BA-F Plus | [kN] | - | - | 12.6* | 12.6* | 20.4* | 20.4* | - | 30.0* | 30.0* | 54.1* |
| | BA-E Plus / BA-E Plus HCR | [kN] | - | - | 15.8* | 15.8* | 20.4* | 20.4* | - | 34.4* | 34.4* | 68.6* |
| | BA-C NC | [kN] | 5.4 | 7.0* | - | - | - | - | 13.0 | - | 20.0 | 34.0 |
| Cracked concrete | | | | | | | | | | | | |
| Tensile N_{Rk} | BA-V Plus / BA-F Plus | [kN] | - | - | 5.0 | 8.5 | 8.7 | 12.0 | - | 12.2 | 16.0 | 24.0 |
| | BA-E Plus / BA-E Plus HCR | [kN] | - | - | 5.0 | 8.5 | 8.7 | 12.0 | - | 12.2 | 16.0 | 24.0 |
| Shear V_{Rk} | BA-V Plus / BA-F Plus | [kN] | - | - | 12.6* | 12.6* | 20.4* | 20.4* | - | 34.6 | 30.0* | 54.1* |
| | BA-E Plus / BA-E Plus HCR | [kN] | - | - | 15.8* | 15.8* | 20.4* | 20.4* | - | 34.6 | 34.4* | 73.1 |

*Failure mode = steel; ¹No ETA

Design resistances

| Anchor size | | M8 x 50 ¹ | M8 [Opt. 7] | M8 | M10 | M10 [Opt. 7] | M12 | M16 | | | | |
|------------------------------------|---------------------------|----------------------|----------------|-------|-------|-----------------|-------|-------|------|-------|-------|-------|
| Effective anchorage depth h_{ef} | | [mm] | 23 | 43 | 35 | 48 | 40 | 60 | 50 | 50 | 70 | 85 |
| Non-cracked concrete | | | | | | | | | | | | |
| Tensile N_{Rd} | BA-V Plus / BA-F Plus | [kN] | - | - | 5.3 | 7.3 | 8.0 | 12.7 | - | 11.6 | 16.7 | 24.0 |
| | BA-E Plus / BA-E Plus HCR | [kN] | - | - | 5.3 | 7.3 | 8.0 | 12.7 | - | 11.6 | 16.7 | 24.0 |
| | BA-C NC | [kN] | 2.4 | 6.1 | - | - | - | - | 8.7 | - | 9.4 | 14.7 |
| Shear V_{Rd} | BA-V Plus / BA-F Plus | [kN] | - | - | 10.1* | 10.1* | 16.3* | 16.3* | - | 24.0* | 24.0* | 43.3* |
| | BA-E Plus / BA-E Plus HCR | [kN] | - | - | 12.6* | 12.6* | 16.3* | 16.3* | - | 27.5* | 27.5* | 54.9* |
| | BA-C NC | [kN] | 3.6 | 5.18* | - | - | - | - | 8.68 | - | 15.82 | 22.68 |
| Cracked concrete | | | | | | | | | | | | |
| Tensile N_{Rd} | BA-V Plus / BA-F Plus | [kN] | - | - | 3.3 | 5.7 | 5.8 | 8.0 | - | 8.1 | 10.7 | 16.0 |
| | BA-E Plus / BA-E Plus HCR | [kN] | - | - | 3.3 | 5.7 | 5.8 | 8.0 | - | 8.1 | 10.7 | 16.0 |
| Shear V_{Rd} | BA-V Plus / BA-F Plus | [kN] | - | - | 10.1* | 10.1* | 16.3* | 16.3* | - | 23.1 | 24.0* | 43.3* |
| | BA-E Plus / BA-E Plus HCR | [kN] | - | - | 10.5 | 12.6* | 16.3* | 16.3* | - | 23.1 | 27.5* | 48.7 |

*Failure mode = steel; ¹No ETA

The data of these tables is based on:

- > Concrete C20/25, $f_{ck,cube} = 25 \text{ N/mm}^2$
- > Installation has been done correctly
- > No influence of edge distances and spacings
- > Respect of minimum base material thickness

Static and quasi-static loads

Recommended loads

| Anchor size | | M8 x 50 ¹ | M8 [Opt. 7] | M8 | M10 | M10 [Opt. 7] | M12 | M16 | | | | |
|------------------------------------|---------------------------|----------------------|----------------|------|------|-----------------|-------|-------|-----|-------|-------|-------|
| Effective anchorage depth h_{ef} | | [mm] | 23 | 43 | 35 | 48 | 40 | 60 | 50 | 50 | 70 | 85 |
| Non-cracked concrete | | | | | | | | | | | | |
| Tensile N_{Rec} | BA-V Plus / BA-F Plus | [kN] | - | - | 3.8 | 5.2 | 5.7 | 9.0 | - | 8.3 | 11.9 | 17.1 |
| | BA-E Plus / BA-E Plus HCR | [kN] | - | - | 3.8 | 5.2 | 5.7 | 9.0 | - | 8.3 | 11.9 | 17.1 |
| | BA-C-NC | [kN] | 1.7 | 4.4 | - | - | - | - | 6.2 | - | 6.7 | 10.5 |
| Shear V_{Rec} | BA-V Plus / BA-F Plus | [kN] | - | - | 7.2* | 7.2* | 11.7* | 11.7* | - | 17.1* | 17.1* | 30.9* |
| | BA-E Plus / BA-E Plus HCR | [kN] | - | - | 9.0* | 9.0* | 11.7* | 11.7* | - | 19.7* | 19.7* | 39.2* |
| | BA-C-NC | [kN] | 2.6 | 3.7* | - | - | - | - | 6.2 | - | 11.3 | 16.2 |
| Cracked concrete | | | | | | | | | | | | |
| Tensile N_{Rec} | BA-V Plus / BA-F Plus | [kN] | - | - | 2.4 | 4.0 | 4.1 | 5.7 | - | 5.8 | 7.6 | 11.4 |
| | BA-E Plus / BA-E Plus HCR | [kN] | - | - | 2.4 | 4.0 | 4.1 | 5.7 | - | 5.8 | 7.6 | 11.4 |
| Shear V_{Rec} | BA-V Plus / BA-F Plus | [kN] | - | - | 7.2* | 7.2* | 11.7* | 11.7* | - | 16.5 | 17.1* | 30.9* |
| | BA-E Plus / BA-E Plus HCR | [kN] | - | - | 7.5 | 9.0* | 11.7* | 11.7* | - | 16.5 | 19.7* | 34.8 |

*Failure mode = steel; ¹No ETA

The data of these tables is based on:

- > Concrete C20/25, $f_{ck,cube} = 25 \text{ N/mm}^2$
- > Installation has been done correctly
- > No influence of edge distances and spacings
- > Respect of minimum base material thickness

Seismic resistance (only BA Plus)

Design acc. EOTA TR 045: Performance category C2



Characteristic resistances

| Anchor size | | | M8 (C2) | M10 (C2) | M12 (C2) | M16 (C2) |
|------------------------------------|-----------|------|---------|----------|----------|----------|
| Effective anchorage depth h_{ef} | | [mm] | 48 | 60 | 70 | 85 |
| Cracked concrete | | | | | | |
| Tensile $N_{Rk, seiss}$ | BA-V Plus | [kN] | 1.7 | 2.7 | 2.8 | 10.2 |
| | BA-E Plus | [kN] | 3.6 | 3.2 | 3.3 | 11.1 |
| Shear $V_{Rk, seiss}$ | BA-V Plus | [kN] | 4.8* | 4.3* | 6.9* | 15.4* |
| | BA-E Plus | [kN] | 4.2* | 4.7* | 7.2* | 15.4* |

Design resistance

| Anchor size | | | M8 (C2) | M10 (C2) | M12 (C2) | M16 (C2) |
|------------------------------------|-----------|------|---------|----------|----------|----------|
| Effective anchorage depth h_{ef} | | [mm] | 48 | 60 | 70 | 85 |
| Cracked concrete | | | | | | |
| Tensile $N_{Rd, seiss}$ | BA-V Plus | [kN] | 1.1 | 1.8 | 1.9 | 6.8 |
| | BA-E Plus | [kN] | 2.4 | 2.1 | 2.2 | 7.4 |
| Shear $V_{Rd, seiss}$ | BA-V Plus | [kN] | 3.8* | 3.4* | 5.5* | 12.3* |
| | BA-E Plus | [kN] | 3.4* | 3.8* | 5.8* | 12.3* |

Recommended loads

| Anchor size | | | M8 (C2) | M10 (C2) | M12 (C2) | M16 (C2) |
|------------------------------------|-----------|------|---------|----------|----------|----------|
| Effective anchorage depth h_{ef} | | [mm] | 48 | 60 | 70 | 85 |
| Cracked concrete | | | | | | |
| Tensile $N_{Rec, seiss}$ | BA-V Plus | [kN] | 0.8 | 1.3 | 1.3 | 4.9 |
| | BA-E Plus | [kN] | 1.7 | 1.5 | 1.6 | 5.3 |
| Shear $V_{Rec, seiss}$ | BA-V Plus | [kN] | 2.7* | 2.4* | 3.9* | 8.8* |
| | BA-E Plus | [kN] | 2.4* | 2.7* | 4.1* | 8.8* |

α_{seis} and α_{gap} included as per EOTA TR 045. The values don't consider any filling of the annular gap between the anchor and the fixture

* Failure mode = steel

The data of these tables is based on:

- > Concrete C20/25, $f_{ck, cube} = 25 \text{ N/mm}^2$
- > Installation has been done correctly
- > No influence of edge distances and spacings
- > Respect of minimum base material thickness

Fire resistance (only BA Plus)



Characteristic resistances

| Anchor size | | | M8 | M10 | M12 | M16 | | | |
|------------------------------------|---------------------------|------|------|------|------|------|------|-------|-------|
| Effective anchorage depth h_{ef} | | [mm] | 35 | 48 | 40 | 60 | 50 | 70 | 85 |
| R30 | | | | | | | | | |
| Tensile $N_{Rk,fi}$ | BA-V Plus / BA-F Plus | [kN] | 1.25 | 1.31 | 1.82 | 2.09 | 3.05 | 3.05 | 5.69 |
| | BA-E Plus / BA-E Plus HCR | [kN] | 1.25 | 2.13 | 1.82 | 3.00 | 3.18 | 4.00 | 6.00 |
| Shear $V_{Rk,fi}$ | BA-V Plus / BA-F Plus | [kN] | 1.31 | 1.31 | 2.09 | 2.09 | 3.05 | 3.05 | 5.69 |
| | BA-E Plus / BA-E Plus HCR | [kN] | 2.76 | 3.92 | 6.02 | 6.66 | 9.03 | 10.25 | 19.09 |
| R60 | | | | | | | | | |
| Tensile $N_{Rk,fi}$ | BA-V Plus / BA-F Plus | [kN] | 1.05 | 1.05 | 1.66 | 1.66 | 2.40 | 2.40 | 4.47 |
| | BA-E Plus / BA-E Plus HCR | [kN] | 1.25 | 2.13 | 1.82 | 3.00 | 3.18 | 4.00 | 6.00 |
| Shear $V_{Rk,fi}$ | BA-V Plus / BA-F Plus | [kN] | 1.05 | 1.05 | 1.66 | 1.66 | 2.40 | 2.40 | 4.47 |
| | BA-E Plus / BA-E Plus HCR | [kN] | 2.70 | 2.70 | 4.59 | 4.59 | 7.07 | 7.07 | 13.16 |
| R90 | | | | | | | | | |
| Tensile $N_{Rk,fi}$ | BA-V Plus / BA-F Plus | [kN] | 0.80 | 0.80 | 1.24 | 1.24 | 1.74 | 1.74 | 3.25 |
| | BA-E Plus / BA-E Plus HCR | [kN] | 1.25 | 1.48 | 1.82 | 2.52 | 3.18 | 3.88 | 6.00 |
| Shear $V_{Rk,fi}$ | BA-V Plus / BA-F Plus | [kN] | 0.80 | 0.80 | 1.24 | 1.24 | 1.74 | 1.74 | 3.25 |
| | BA-E Plus / BA-E Plus HCR | [kN] | 1.48 | 1.48 | 2.52 | 2.52 | 3.88 | 3.88 | 7.23 |
| R120 | | | | | | | | | |
| Tensile $N_{Rk,fi}$ | BA-V Plus / BA-F Plus | [kN] | 0.67 | 0.67 | 1.02 | 1.02 | 1.41 | 1.41 | 2.64 |
| | BA-E Plus / BA-E Plus HCR | [kN] | 0.87 | 0.87 | 1.46 | 1.48 | 2.29 | 2.29 | 4.26 |
| Shear $V_{Rk,fi}$ | BA-V Plus / BA-F Plus | [kN] | 0.67 | 0.67 | 1.02 | 1.02 | 1.41 | 1.41 | 2.64 |
| | BA-E Plus / BA-E Plus HCR | [kN] | 0.87 | 0.87 | 1.48 | 1.48 | 2.29 | 2.29 | 4.26 |

The data of these tables is based on:

- > In the absence of other national regulations the partial safety factor or resistance under fire exposure $\gamma_{M,fi} = 1,0$ is recommended
- > Concrete C20/25, $f_{ck,cube} = 25 \text{ N/mm}^2$
- > Installation has been done correctly
- > No influence of edge distances and spacings
- > Respect of minimum base material thickness

Fire resistance (only BA Plus)



Recommended loads

| Anchor size | | | M8 | M10 | M12 | M16 | | | |
|------------------------------------|---------------------------|------|------|------|------|------|------|-------|-------|
| Effective anchorage depth h_{ef} | | [mm] | 35 | 48 | 40 | 60 | 50 | 70 | 85 |
| R30 | | | | | | | | | |
| Tensile $N_{Rec, fi}$ | BA-V Plus / BA-F Plus | [kN] | 1.25 | 1.31 | 1.82 | 2.09 | 3.05 | 3.05 | 5.69 |
| | BA-E Plus / BA-E Plus HCR | [kN] | 1.25 | 2.13 | 1.82 | 3.00 | 3.18 | 4.00 | 6.00 |
| Shear $V_{Rec, fi}$ | BA-V Plus / BA-F Plus | [kN] | 1.31 | 1.31 | 2.09 | 2.09 | 3.05 | 3.05 | 5.69 |
| | BA-E Plus / BA-E Plus HCR | [kN] | 2.76 | 3.92 | 6.02 | 6.66 | 9.03 | 10.25 | 19.09 |
| R60 | | | | | | | | | |
| Tensile $N_{Rec, fi}$ | BA-V Plus / BA-F Plus | [kN] | 1.05 | 1.05 | 1.66 | 1.66 | 2.40 | 2.40 | 4.47 |
| | BA-E Plus / BA-E Plus HCR | [kN] | 1.25 | 2.13 | 1.82 | 3.00 | 3.18 | 4.00 | 6.00 |
| Shear $V_{Rec, fi}$ | BA-V Plus / BA-F Plus | [kN] | 1.05 | 1.05 | 1.66 | 1.66 | 2.40 | 2.40 | 4.47 |
| | BA-E Plus / BA-E Plus HCR | [kN] | 2.70 | 2.70 | 4.59 | 4.59 | 7.07 | 7.07 | 13.16 |
| R90 | | | | | | | | | |
| Tensile $N_{Rec, fi}$ | BA-V Plus / BA-F Plus | [kN] | 0.80 | 0.80 | 1.24 | 1.24 | 1.74 | 1.74 | 3.25 |
| | BA-E Plus / BA-E Plus HCR | [kN] | 1.25 | 1.48 | 1.82 | 2.52 | 3.18 | 3.88 | 6.00 |
| Shear $V_{Rec, fi}$ | BA-V Plus / BA-F Plus | [kN] | 0.80 | 0.80 | 1.24 | 1.24 | 1.74 | 1.74 | 3.25 |
| | BA-E Plus / BA-E Plus HCR | [kN] | 1.48 | 1.48 | 2.52 | 2.52 | 3.88 | 3.88 | 7.23 |
| R120 | | | | | | | | | |
| Tensile $N_{Rec, fi}$ | BA-V Plus / BA-F Plus | [kN] | 0.67 | 0.67 | 1.02 | 1.02 | 1.41 | 1.41 | 2.64 |
| | BA-E Plus / BA-E Plus HCR | [kN] | 0.87 | 0.87 | 1.46 | 1.48 | 2.29 | 2.29 | 4.26 |
| Shear $V_{Rec, fi}$ | BA-V Plus / BA-F Plus | [kN] | 0.67 | 0.67 | 1.02 | 1.02 | 1.41 | 1.41 | 2.64 |
| | BA-E Plus / BA-E Plus HCR | [kN] | 0.87 | 0.87 | 1.48 | 1.48 | 2.29 | 2.29 | 4.26 |

The data of these tables is based on:

- > In the absence of other national regulations the partial safety factor or resistance under fire exposure $\gamma_{M, fi} = 1,0$ is recommended
- > Concrete C20/25, $f_{ck, cube} = 25 \text{ N/mm}^2$
- > Installation has been done correctly
- > No influence of edge distances and spacings
- > Respect of minimum base material thickness

Material and dimensions

BA Plus Anchor dimensions

| Anchor size | | | M8 | M10 | M12 | M16 |
|---------------|------------------|------|----------|----------|----------|-----------|
| Total length | L | [mm] | 57 – 420 | 62 – 420 | 78 – 420 | 118 – 420 |
| Sleeve length | L _s | [mm] | 14.8 | 17.9 | 19.1 | 26.0 |
| Bolt body | d _{nom} | [mm] | 8 | 10 | 12 | 16 |
| Hexagonal nut | SW | [mm] | 13 | 17 | 19 | 24 |
| | m | | ≥ 6.5 | ≥ 8.0 | ≥ 10.0 | ≥ 13.0 |

BA-C NC Anchor dimensions

| Anchor size | | | M8 | M10 | M12 | M16 |
|---------------|------------------|------|----------|----------|-----------|-----------|
| Total length | L | [mm] | 50 – 135 | 85 – 215 | 110 – 320 | 135 – 320 |
| Sleeve length | L _s | [mm] | 14.4 | 16.5 | 19.0 | 23.0 |
| Bolt body | d _{nom} | [mm] | 8.0 | 10.0 | 12.0 | 16.0 |
| Hexagonal nut | SW | [mm] | 13.0 | 17.0 | 19.0 | 24.0 |

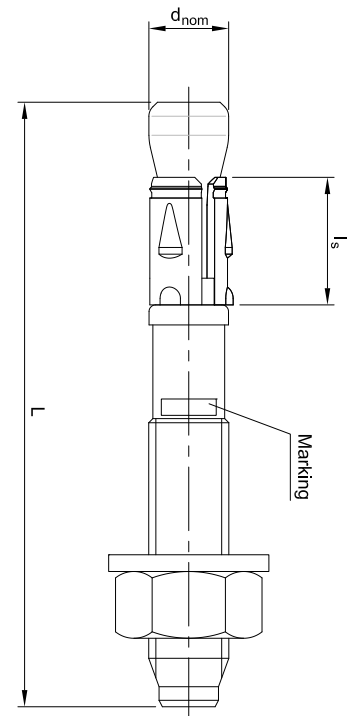

Mechanical properties

| Specifications | | Anchor / size | | M8 | M10 | M12 | M16 |
|--------------------------------|--------------------------------|---------------------------|----------------------|-------|-------|-------|-------|
| Nominal tensile strength | f _{uk, thread} | BA-V Plus / BA-F Plus | [N/mm ²] | 700 | 690 | 690 | 660 |
| | | BA-E Plus / BA-E Plus HCR | [N/mm ²] | 670 | 690 | 690 | 645 |
| | | BA-C NC | [N/mm ²] | ≥ 550 | ≥ 670 | ≥ 630 | ≥ 600 |
| Char. bending resistance | M ⁰ _{Rk,s} | BA-V Plus / BA-F Plus | [Nm] | 26.3 | 51 | 90 | 219.8 |
| | | BA-E Plus / BA-E Plus HCR | [Nm] | 25.1 | 51 | 90 | 214.8 |
| | | BA-C NC | [Nm] | 12.0 | 25.6 | 45.1 | 104.4 |
| Design bending resistance | M _{Rd,s} | BA-V Plus / BA-F Plus | [kN] | 21.0 | 40.8 | 72.0 | 175.8 |
| | | BA-E Plus / BA-E Plus HCR | [kN] | 20.1 | 40.8 | 72.0 | 171.8 |
| | | BA-C NC | [kN] | 10.0 | 17.1 | 35.8 | 69.6 |
| Recommended bending resistance | M _{Rec} | BA-V Plus / BA-F Plus | [kN] | 15.0 | 29.1 | 51.4 | 125.6 |
| | | BA-E Plus / BA-E Plus HCR | [kN] | 14.3 | 29.1 | 51.4 | 122.7 |
| | | BA-C NC | [kN] | 6.4 | 12.2 | 25.6 | 49.7 |

Material quality

| Part of anchor | Anchor | Material |
|----------------|---------------------|-------------------------------------|
| Bolt | BA-V Plus / BA-C NC | Carbon steel, zinc electroplated |
| | BA-F Plus | Carbon steel, hot dip galvanized |
| | BA-E Plus | Stainless steel A4 |
| | BA-E Plus HCR | Stainless steel HCR 1.4529 / 1.4565 |

Installation instructions

Installation equipments

| Specification | M8 | M10 | M12 | M16 |
|--------------------------------|---|-----|-----------------|---------------------------------|
| | 720 – 1200 U/min / 1.8 – 3.3 J | | | |
| Rotary hammer (reccomendation) | | | | 360 – 550 r.p.m 4.9 – 11.5 J |
| Setting tool (optional) | BA-V 6-10 SDS+ | | BA-V 12-20 SDS+ | |
| Drill bit | SDS+ 2-cut/4-cut 8 mm – 16 mm | | | |
| Additional tools | brush, air pump/compressor, hammer, torque wrench | | | |

Installation data

| Parameters and anchors sizes | | M8 x 50 ¹ | M8 | M10 | M12 | M16 | | | | |
|--|---------------------------|--------------------------|------|------|-------|-------|-------|----|----|-----|
| Drill hole diameter d_0 | BA-Plus | d_0 [mm] | - | 8 | 10 | 12 | 16 | | | |
| | BA-C NC | | 8 | | | | | | | |
| Cutting diameter at the upper tolerance limit (max. diam. bit) | BA-Plus | $d_{cut, max} \leq$ [mm] | - | 8.45 | 10.45 | 12.50 | 16.50 | | | |
| | BA-C NC | | 8.45 | | | | | | | |
| Depth of drilled hole to deepest point | BA-Plus | $h_1 \geq$ [mm] | - | 47 | 60 | 55 | 75 | 70 | 90 | 110 |
| | BA-C NC | | 38 | 63 | 69 | 92 | 109 | | | |
| Effective anchorage depth | BA-Plus | h_{ef} [mm] | - | 35 | 48 | 40 | 60 | 50 | 70 | 85 |
| | BA-C NC | | 23 | 43 | 50 | 70 | 85 | | | |
| Nominal anchorage depth | BA-Plus | h_{nom} [mm] | - | 40 | 53 | 48 | 68 | 61 | 81 | 97 |
| Diameter of clearance hole in the fixture | BA-Plus | d_f [mm] | - | 9 | 12 | 14 | 18 | | | |
| | BA-C NC | | 9 | | | | | | | |
| Width across flats | BA-Plus | SW [mm] | - | 13 | 17 | 19 | 24 | | | |
| | BA-C NC | | 13 | | | | | | | |
| Required torque | BA-V Plus / BA-F Plus | T_{inst} [Nm] | - | 15 | 30 | 60 | 110 | | | |
| | BA-E Plus / BA-E Plus HCR | | - | 20 | 45 | 60 | 110 | | | |
| | BA-C NC | | 13 | 15 | 30 | 50 | 90 | | | |

¹No ETA

Installation methods

Through installation

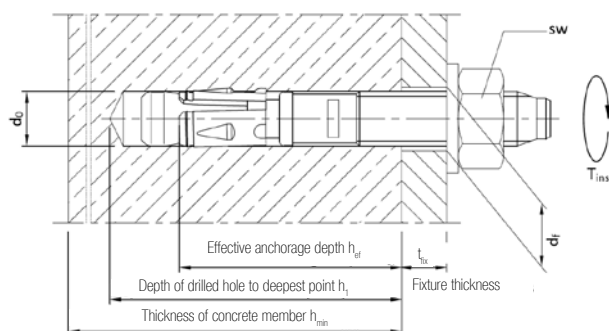

Distance installation

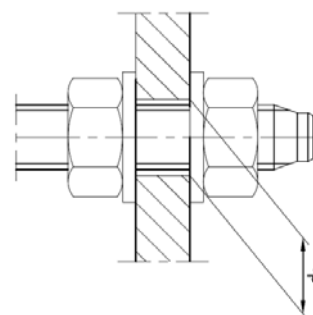

Installation parameters

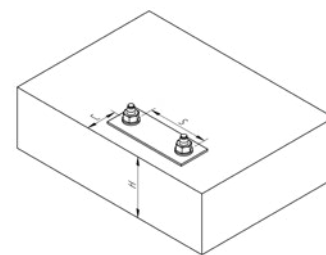

BA Plus Range

Minimum thickness of concrete member, spacing and edge distance

| Cracked and non-cracked concrete | | | M8 | M10 | M12 | M16 | | | |
|--|---------------|------|-----|-----|-----|-----|-----|-----|-----|
| Effective anchorage depth | h_{ef} | [mm] | 35 | 48 | 40 | 60 | 50 | 70 | 85 |
| Minimum thickness of base material | h_{min} | [mm] | 80 | 100 | 100 | 120 | 100 | 140 | 170 |
| | $h_{min-red}$ | [mm] | - | 80 | - | 100 | - | - | - |
| Minimum spacing for h_{min} | s_{min} | [mm] | 55 | 35 | 50 | 40 | 55 | 60 | 65 |
| | $c \geq$ | [mm] | 75 | 50 | 95 | 60 | 110 | 70 | 95 |
| Minimum edge distance for h_{min} | c_{min} | [mm] | 40 | 40 | 50 | 50 | 60 | 55 | 65 |
| | $s \geq$ | [mm] | 140 | 55 | 190 | 100 | 215 | 110 | 150 |
| Minimum spacing for $h_{min-red}$ | s_{min} | [mm] | - | 35 | - | 40 | - | - | - |
| | $c \geq$ | [mm] | - | 55 | - | 100 | - | - | - |
| Minimum edge distance for h_{min} | c_{min} | [mm] | - | 40 | - | 60 | - | - | - |
| | $S \geq$ | [mm] | - | 60 | - | 90 | - | - | - |
| Critical spacing for splitting failure and concrete cone failure (in case characteristic loading affects) | $s_{cr,sp}$ | [mm] | 170 | 192 | 160 | 240 | 200 | 280 | 340 |
| | $s_{cr,N}$ | [mm] | 106 | 144 | 120 | 180 | 150 | 210 | 254 |
| Critical edge distance for splitting failure and concrete cone failure (in case characteristic loading affects) | $c_{cr,sp}$ | [mm] | 85 | 96 | 80 | 120 | 100 | 140 | 170 |
| | $c_{cr,N}$ | [mm] | 53 | 72 | 60 | 90 | 75 | 105 | 127 |

BA-C NC

Minimum thickness of concrete member, spacing and edge distance

| Non-cracked concrete (Option 7) | | | M8 x 50 ¹ | M8 | M10 | M12 | M16 |
|-------------------------------------|-----------|------|----------------------|-----|-----|-----|-----|
| Effective anchorage depth | h_{ef} | [mm] | 23 | 43 | 50 | 70 | 85 |
| Minimum thickness of base material | h_{min} | [mm] | 100 | 100 | 120 | 150 | 160 |
| Minimum spacing for h_{min} | s_{min} | [mm] | 90 | 50 | 100 | 120 | 140 |
| Minimum edge distance for h_{min} | c_{min} | [mm] | 50 | 50 | 90 | 100 | 125 |

¹No ETA

Setting instructions

Installation

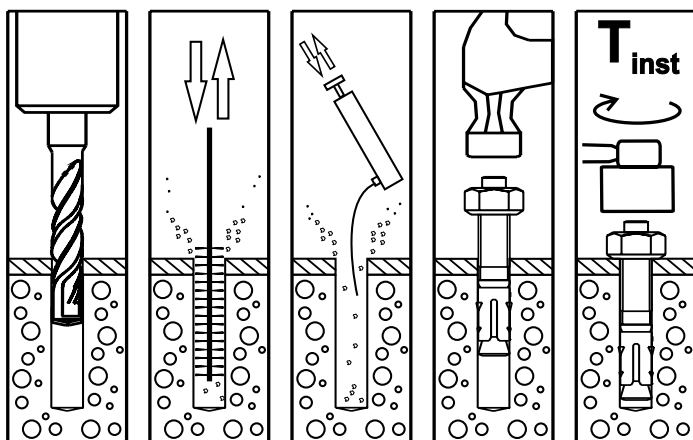

1. Drill a hole according to the product data.
- 2.-3. Clean the hole using a metal brush and a blow-out pump.
4. Install anchor with a hammer or a setting tool.
5. Tighten the anchor to the specified installation torque.

Accessories

Setting tool BA

Hammering tool to make through bolt installation quicker and smoother

- > Original EJOT through bolts setting tool with designed head that does not damage the head of the anchor and keep the head from slipping.
- > Besides ensuring most efficient and safe through bolt installation in general, the setting tool also significantly saves time and energy in serial installation.
- > Compatible with all SDS+ chuck machines.



Delivery program

| Thread size | Type | t _{fix} | Length | BA-V Plus | BA-F Plus | BA-E Plus | BA-E Plus HCR | BA-C-NC |
|-------------|-----------|------------------|--------|-----------|-----------|--------------------|---------------|---------|
| | | | | Zinc | Hot dip | Stainless steel A4 | HCR | Zinc |
| M8 | M8/5/- | 5 | 57 | • | • | • | • | - |
| | M8/23/10 | 23/10 | 75 | • | • | • | • | • |
| | M8/43/30 | 43/30 | 95 | • | • | • | • | • |
| | M8/63/50 | 63/50 | 115 | • | • | • | • | • |
| | M8/98/85 | 98/85 | 150 | • | • | • | • | - |
| M10 | M10/10/- | 10 | 72 | • | • | • | • | - |
| | M10/10 | 10 | 85 | - | - | - | - | • |
| | M10/30/10 | 30/10 | 92 | • | • | • | • | - |
| | M10/20 | 20 | 95 | - | - | - | - | • |
| | M10/40/20 | 40/20 | 102 | • | • | • | • | - |
| | M10/30 | 30 | 105 | - | - | - | - | • |
| | M10/50/30 | 50/30 | 112 | • | • | • | • | - |
| | M10/50 | 50 | 125 | - | - | - | - | • |
| | M10/70/50 | 70/50 | 132 | • | • | • | • | - |
| M10/100/80 | 100/80 | 162 | • | • | • | • | - | |
| M12 | M12/10/- | 10 | 88 | • | • | • | • | - |
| | M12/25/5 | 25/5 | 103 | • | • | • | • | - |
| | M12/10 | 10 | 110 | - | - | - | - | • |
| | M12/40/20 | 40/20 | 118 | • | • | • | • | - |
| | M12/20 | 20 | 120 | - | - | - | - | • |
| | M12/30 | 30 | 130 | - | - | - | - | • |
| | M12/70/50 | 70/50 | 148 | • | • | • | • | - |
| | M12/50 | 50 | 150 | - | - | - | - | • |
| | M12/85/65 | 85/65 | 163 | • | • | • | • | - |
| M12/100/80 | 100/80 | 178 | • | • | • | • | - | |
| M16 | M16/5 | 5 | 123 | • | • | • | • | - |
| | M16/10 | 10 | 135 | - | - | - | - | • |
| | M16/20 | 20 | 138 | • | • | • | • | - |
| | M16/20 | 20 | 145 | - | - | - | - | • |
| | M16/50 | 50 | 168 | • | • | • | • | - |
| | M16/50 | 50 | 175 | - | - | - | - | • |
| | M16/60 | 60 | 178 | • | • | • | • | - |

• On request

Note: Diameter M6 for multiple use for non-structural applications in concrete available on demand.

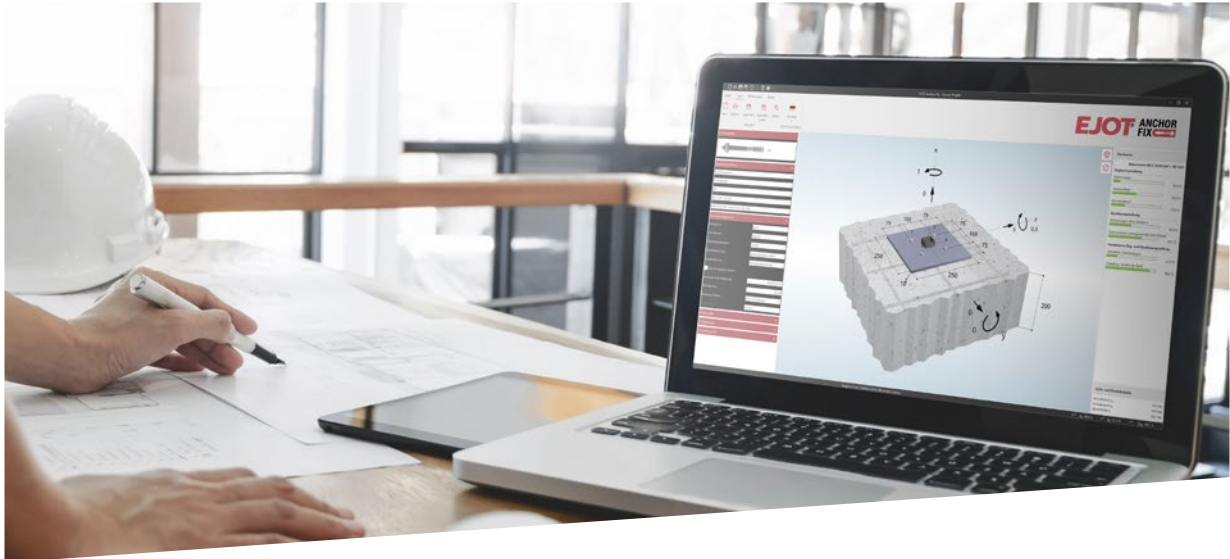

Software solution

EJOT ANCHOR FIX® – anchor dimensioning made easy

With the brand new EJOT ANCHOR FIX® version, the free dimensioning software for anchoring, EJOT is offering a very helpful tool for the static dimensioning of anchoring in your projects. Specially developed for structural engineers, specifiers, engineers and technicians, the software can also be used as a handy guide in the pre-planning phase.

With EJOT ANCHOR FIX®, the limits of the load-carrying capacity of EJOT anchoring products such as through bolts and concrete screws in concrete substrates can be determined. Another new feature is the possibility of dimensioning nylon and chemical anchors in concrete and masonry.

CROSSFIX® has also now been fully integrated. In addition, with the new software version, a design for fire and seismic load cases is possible. EJOT ANCHOR FIX® still allows you to directly input data from site extraction tests and their evaluation in accordance with regulations.

EJOT ANCHOR FIX® can be downloaded here:
www.ejot.de/software-anchorfix

The targeted selection of the calculation methods for single vs. multiple fastening of various products offers the user application safety. Planning reliability on the part of the user is achieved by the output of individual quantity requirements for chemical anchors and this also has variable setting levels. All additional documents such as approvals and product data sheets can be easily accessed, directly via the software.

Try it out – free of charge ...

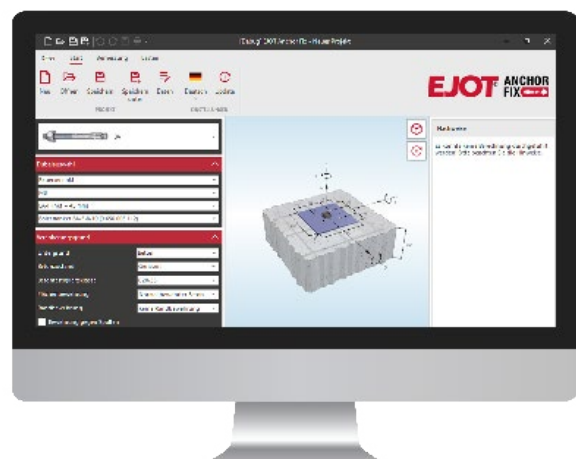



EJOT SE & Co. KG

Market Unit Construction

In der Stockwiese 35

57334 Bad Laasphe · Germany

T +49 2752 908-0

F +49 2752 908-731

construction@ejot.com

www.ejot.com/construction